

# Standard type

The hubs of the standard coupling type can be either solid or have a finished bore, the diameter of which corresponds to any one of the standard shaft diameters. The grubscrew(s) is (are)

located 180° from the key seat - ex. 02 (120° each other - ex. 01). Both the solid hub and bored hub coupling are generally available from stock for quick delivery.

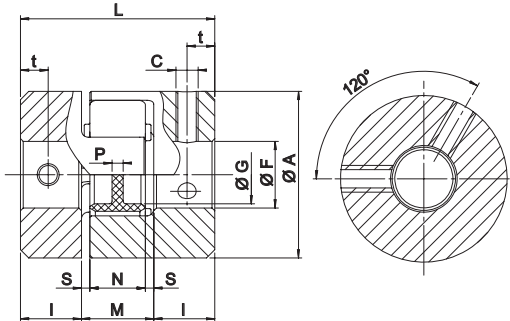

Fig. 1

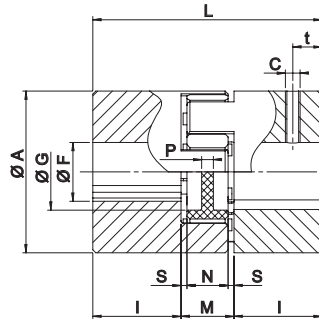

Fig. 2

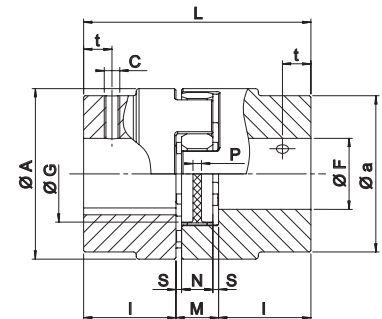

Fig. 3

Type	F min [mm]	F max [mm]	Hub		n <sub>max</sub> [min <sup>-1</sup> ]
			W [kg]	J [kgm <sup>2</sup> ]	
<b>ALUMINUM HUBS</b>					
7	3	7	0,003	0,085 x 10 <sup>-6</sup>	40.000
9	4	9	0,009	0,49 x 10 <sup>-6</sup>	28.000
14	4	14	0,020	2,8 x 10 <sup>-6</sup>	19.000
19/24	6	24	0,066	20,4 x 10 <sup>-6</sup>	14.000
24/28	8	28	0,132	50,8 x 10 <sup>-6</sup>	10.600
28/38	10	38	0,253	200,3 x 10 <sup>-6</sup>	8.500
38/45	12	45	0,455	400,6 x 10 <sup>-6</sup>	7.100
<b>STEEL HUBS</b>					
42	14	55	1,850	2.246 x 10 <sup>-6</sup>	6.000
48	20	60	2,520	3.786 x 10 <sup>-6</sup>	5.600
55	25	70	4,100	9.986 x 10 <sup>-6</sup>	5.000
65	25	80	5,900	18.352 x 10 <sup>-6</sup>	4.600

a [mm]	A [mm]	G [mm]	L [mm]	I [mm]	M [mm]	N [mm]	S [mm]	P [mm]	c	t [mm]	Fig.
<b>ALUMINUM HUBS</b>											
-	14	-	22	7	8	6	1,0	6	M3	3,5	1
-	20	7,2	30	10	10	8	1,0	2	M3	5	1
-	30	10,5	35	11	13	10	1,5	2	M4	5	2
-	40	18	66	25	16	12	2,0	3,5	M5	10	2
-	55	27	78	30	18	14	2,0	4	M5	10	2
-	65	30	90	35	20	15	2,5	5,2	M6	15	2
-	80	38	114	45	24	18	3,0	5,6	M8	15	2
<b>STEEL HUBS</b>											
75	95	46	126	50	26	20	3,0	5,6	M8	20	3
-	105	51	140	56	28	21	3,5	6	M8	25	2
-	120	60	160	65	30	22	4,0	9	M10	20	2
-	135	68	185	75	35	26	4,5	8,3	M10	20	2

Bore tolerance: H7 - JS9 (DIN 6985/1) keyway

## Order form

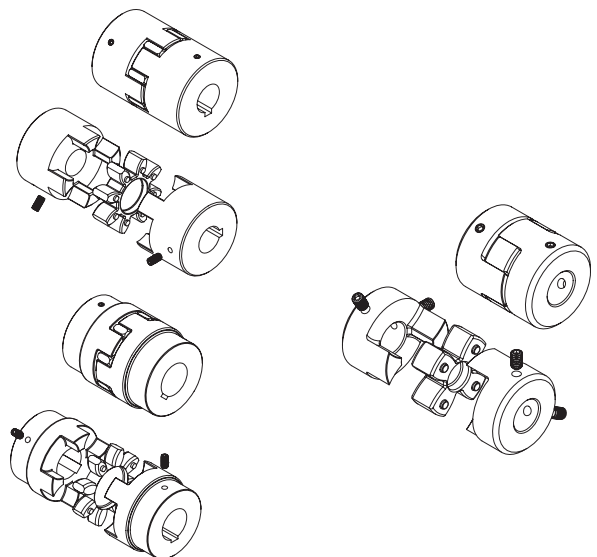
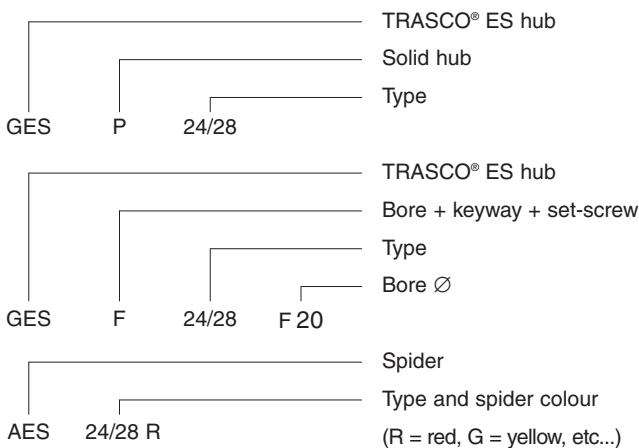

W	Weight	kg
J	Moment of inertia	kgm <sup>2</sup>
n <sub>max</sub>	Maximum rpm	min <sup>-1</sup>